

SISTEMA QUALITA' CERTIFICATO



UNI EN ISO 9001 : 2008

RUBINETTERIE
treemme



Istruzioni di montaggio



Installation Instructions



Instruction de montage

Monocomandi da terra

Floor standing mixer

Mitigeur sur colonne au sol



Grazie per aver scelto Rubinetterie 3M. Perché il Suo rubinetto funzioni correttamente e possa durare nel tempo, occorre che vengano rispettate le procedure di installazione ed manutenzione illustrate in questo opuscolo.

Thank you for selcting Rubinetterie 3M. In order to allow a proper functioning of your fittine and a long-lasting reliability, you must carefully observe our care and installation instruction described on this brochure.

Nous vous remercions d'avoir chiosi Rubinetterie 3M. Afin que cet appareil fonctionne d'une manière correcte et puisse durer longtemps, il convient de respecter les modalités d'installation et d'entretien indiquées dnas cette notice.

Preliminari

Prima di procedere all'installazione è necessario pulire accuratamente le tubature per eliminare eventuali detriti in esse presenti

Preliminary information

Before starting with the installation it is necessari to clean the pipes carefully in order to eliminate any deposit which may be found inside them.

Preliminaires

Avant de monter les mitigeur, il faut bien nettoyer les tuyaux pour éliminer toutes les impuretés à l'intérieur.

Montaggio del corpo incasso

Concealed body assembling

Assemblage du corps d'encastrement

Attenzione: Fare molta attenzione a che il corpo sia perfettamente verticale (controllare con la livella)

Attention: Body must be perfectly vertical check with a spirit level

Attention: The Prêter attention que le corps soit parfaitement vertical (contrôler avec une niveau)

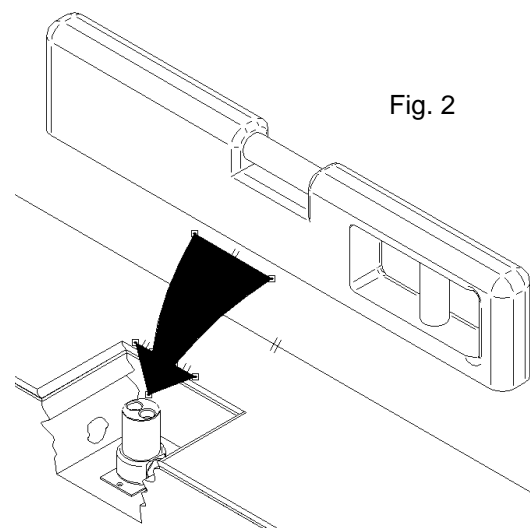
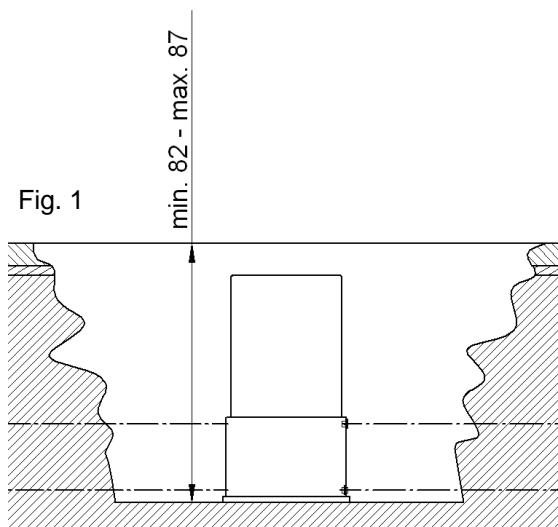

Test impianto

To test plumbing

Pour tester la plomberie

Collegare i tubi, montare i due tappi in dotazione, mettere in pressione l'impianto e verificare l'assenza di perdite d'acqua (Fig. 3)

Connect pipes, screw the plugs, pressurize the system and check for water leak (Fig. 3)

Fixer les arrivés d'eau, visser les deux bouchons, pressuriser le système et vérifier les fuites d'eau.

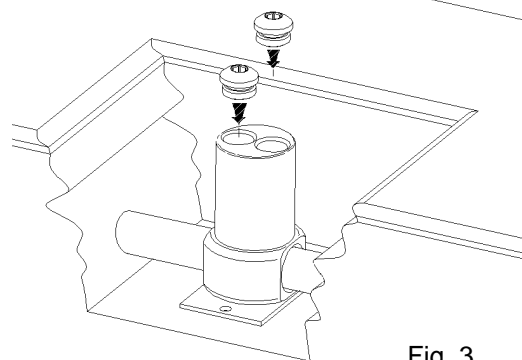

Togliere pressione all'impianto

Depressurize the system

Supprimer la pression du système

Rimuovere i tappi (fig. 4) e avvitare gli attacchi per flessibile (fig. 5). Ripristinare il pavimento.

Remove the plugs (fig. 4) and screw joint for flexible (fig. 5). Fill up until the floor is restored.

Enlever les bouchons (fig. 4) et serrer les raccords pour flexibles (fig.5) restaurer les tuiles.

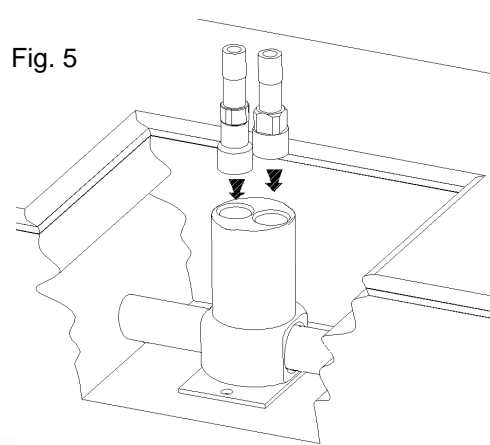
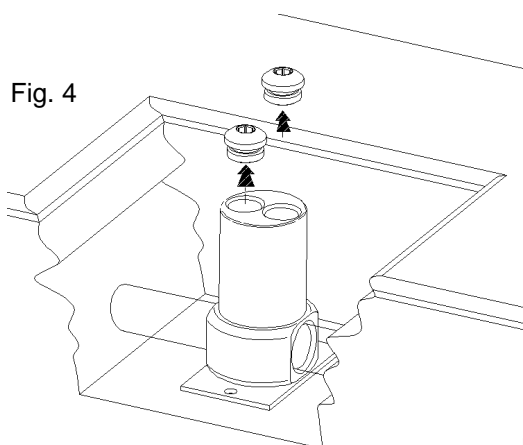

Avvitare i flessibili al corpo rubinetto (fig. 6)

Screw flexibles on the body mixer (fig. 6)

Visser les flexibles sur le corps du mitigeur (fig. 6)

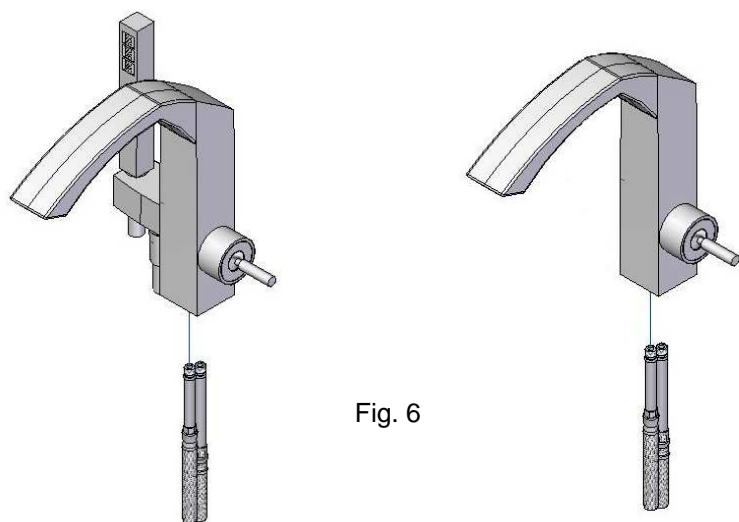

Fig. 6



Inserire il palo (8) al corpo rubinetto (7) e avvitare il grano (1).

Fit in part (8) on the body mixer (7) and tight screw (1).

Insérez le poteau (8) au corps de vanne (7) et serrer le grain (1).

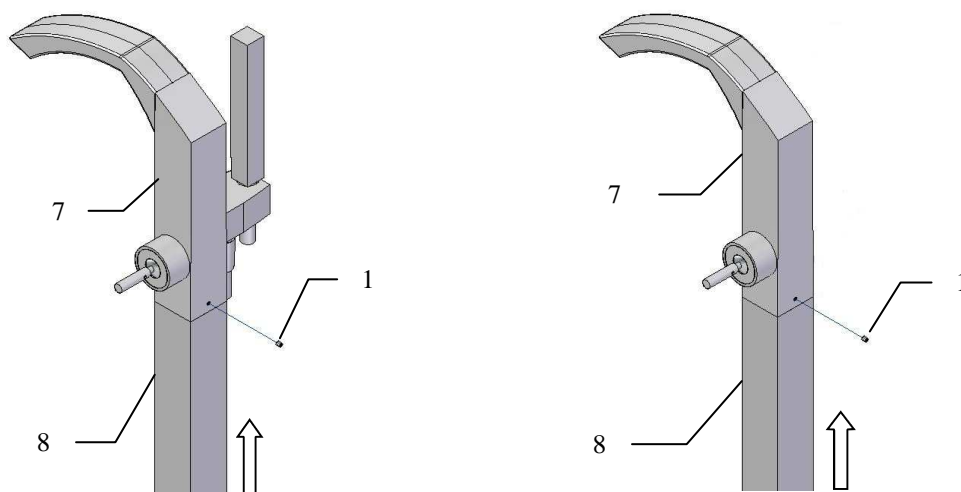
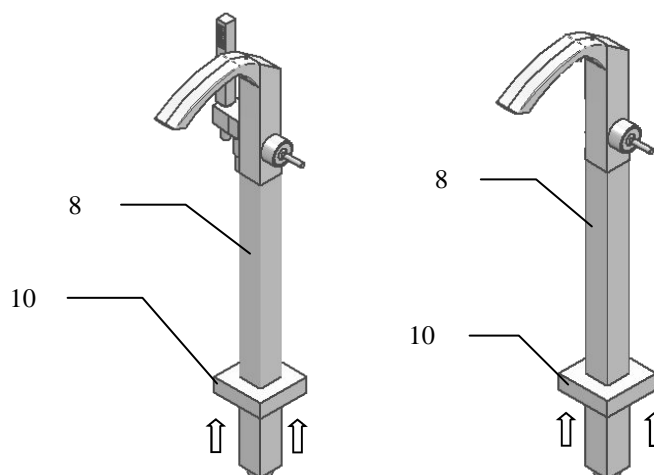

Fig. 8

Far scorrere la flangia (10) sul tubo 8

Insert flange (10) on part (8).

Courir la rosace (10) sur la partie (8)



Avvitare la flangia (9) al palo

Screw part (9).

Visser la partie (9)

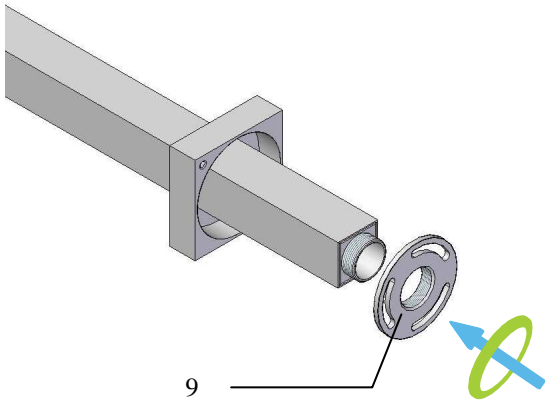

Dopo il montaggio appoggiare la flangia (9) al pavimento e segnare i punti di foratura per tasselli.

After assembly put flange (9) on the floor nad mark the points for drilling.

Après l'assemblage poser la rosace (9) au sol.

Marquer le sol de forage pour chevilles.

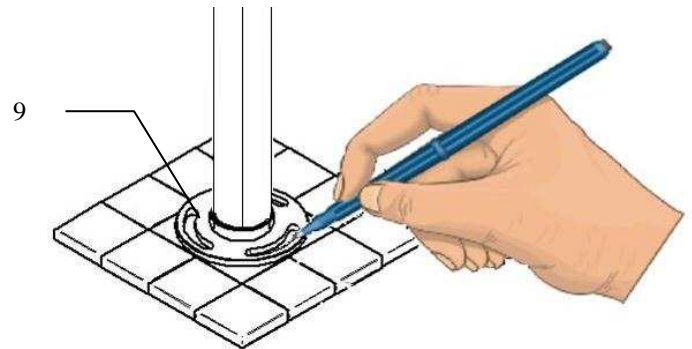

Collegare i flessibili (5) e (6) agli attacchi (4) e serrare la flangia (9) al pavimento con tasselli (non forniti).

Accostare la borchia (10) al paviemto.

Insert flexible (5) and (6) in the parts (4) and fix flange (9) to the floor. Let flange (10) reach the floor as indicated in the drawing.

Raccordez les flexibles (5) et (6) sur les parties (4) et fixer la partie (9). Faire descendre la rosace (10) au sol comme indique par la fiche (fig. 8).

