

FL.341CF-2

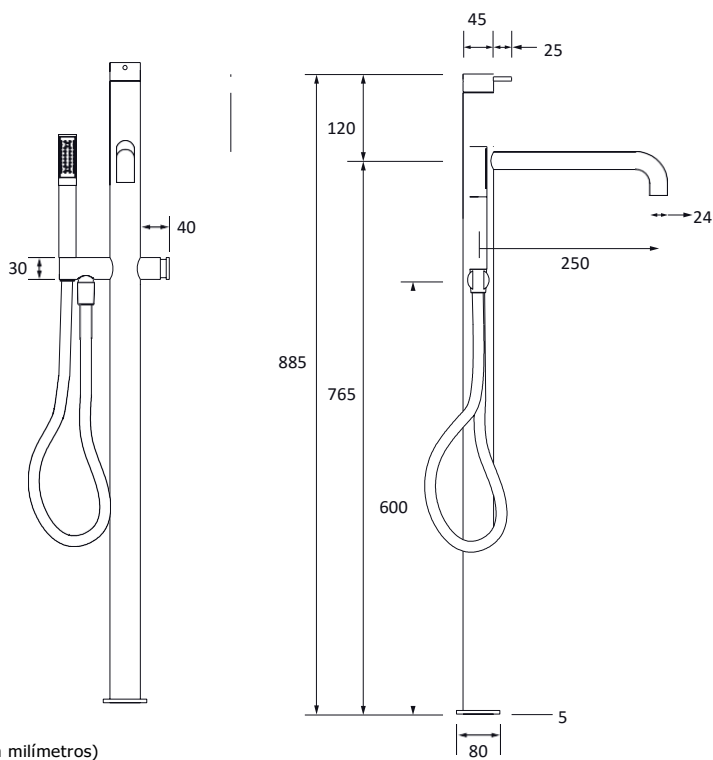

Desenho Técnico | Technical Drawing | Disegno Tecnico
Conception Technique | Diseño Técnico

Características | Technical Features | Caratteristiche
Caractéristiques | Características



(medidas em milímetros)

PT

- Latão
- Acabamento cromado
- Acabamento preto
- Acabamento branco
- Pressão Máxima: 6 bar
- Pressão Recomendada: 3 a 5 bar
- Temperatura Máxima: 80°C

EN

- Brass
- Chromed finish
- Black finish
- White finish
- Maximum Pressure: 6 bar
- Recommended Pressure: 3 a 5 bar
- Maximum Temperature: 80°C
- Volume: 12L/min a 3bar

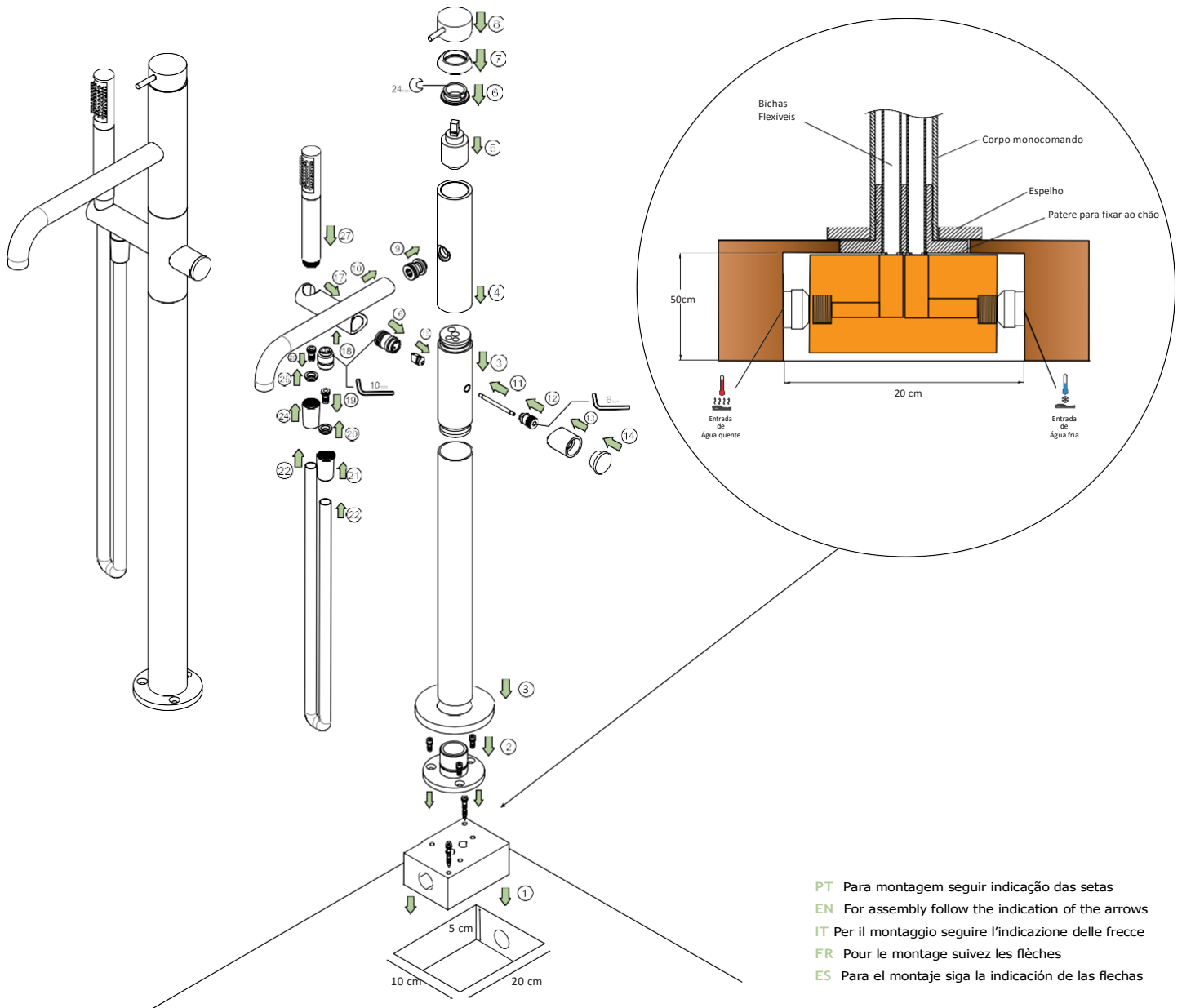

Recomendações de Instalação | Installation Recommendations | Raccomandazioni di Installazione | Recommendations pour l'installation | Recomendaciones de Instalación

EN Before installing a tap, it is good to rinse the supply pipes to remove all residues. We also recommend installing the taps with a filter. The installation of the tap must be done with the surface clean and dry. To perform the water pressure test, the taps must be open.

ES Antes de instalar un grifo, aclarar bien todas las tuberías de alimentación para eliminar los residuos de suciedad. Se aconseja también instalar los grifos provistos de un filtro. La instalación de lo grifo se debe hacer con la superficie limpia y seca. Al realizar la prueba de presión del agua, los grifos deben estar abiertos.

Limpeza e Manutenção | Cleaning and Maintenance | Pulizia e Manutenzione | Nettoyage et Entretien | Limpieza y Mantenimiento

EN Cleaning must be done with liquid soap and water. Do not use liquid detergents containing abrasive or acidic substances, abrasive sponges or disinfectants. The above products also cannot be used in the cleaning of sanitary ware near the taps. Incorrect cleaning may permanently ruin the surface of taps, thus annulling the validity of the Water Evolution warranty.